

TP-K812

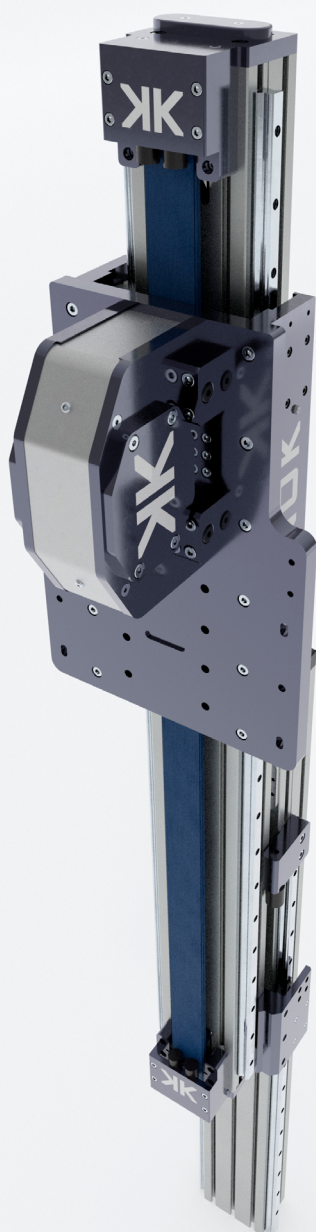

SERIE TP
TP SERIES

SPECIFICHE TECNICHE / TECHNICAL DATA

Versione unità Type Unit	Doppia guida verticale Double vertical guide
Sezione portante Structure Section	80x120
Dimensioni guide Rail Size	20
Cinghia Belt	AT10-50
Velocità Speed	2 (m/sec)
Accelerazione Acceleration	10 (m/sec)
Ripetibilità Repeatability	0.1 (mm)

DATI PULEGGIA / PULLEY DATA

Puleggia Pulley	Z28
Ø Primitivo puleggia Ø Pulley Primitive	89.12 [mm]
Passo per giro puleggia Step for Pulley turn	280 [mm]
Coppia a vuoto Starting Torque	3.0 [Nm]
Rapporto carichi II stadio Load ratio II stage	1:2

PESI / WEIGHTS

Modulo corsa zero Module zero travel	43.0 kg
Peso 100mm corsa (I e II stadio) Weight 100mm stroke (I and II stage)	3.8 kg
Peso carro motore Weight of the motor carriage	21.0 kg
Peso I stadio Weight stage I	10kg + 10kg x (100mm stroke)
Peso II stadio Weight stage II	10kg + 10kg x (100mm stroke)

CONDIZIONI DI ESERCIZIO CONSIGLIATE / RECOMMENDED OPERATING CONDITIONS

Momento dinamico Dynamic Moment	Mx¹ 960 Nm	My¹ 2250 Nm	Mz¹ 2400 Nm	I STADIO STAGE I
Momento dinamico Dynamic Moment	Mx² 310 N	My² 1665 N	Mz² 1700 Nm	II STADIO STAGE II
Carico a trazione Tensile load	Fx 4000 N			

* Il valore Fx si riferisce al carico applicabile alla puleggia, e non al valore di carico ammissibile dalla cinghia. Tale valore è calcolato sulla base del tipo di cinghia e del numero di denti della puleggia.
* The Fx value refers to the load applicable to the pulley, and not to the allowable load value of the belt. This value is calculated on the basis of the type of belt and the number of pulley teeth.

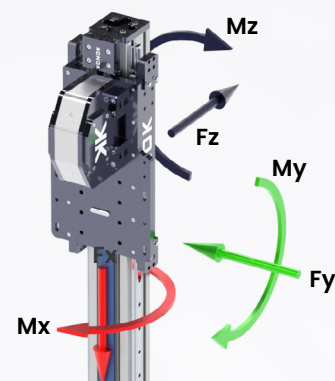

I valori dinamici indicati non corrispondono alle massime capacità di carico teoriche. Sono stati calcolati considerando fattori di sicurezza adatti alle automazioni industriali. In caso di sollecitazioni massime contemporanee si prega di contattare il servizio tecnico.
The dynamic values indicated do not correspond to the theoretical maximum load capacities. They have been calculated considering safety factors suitable for industrial automation. In case of simultaneous maximum stresses, please contact the technical service.

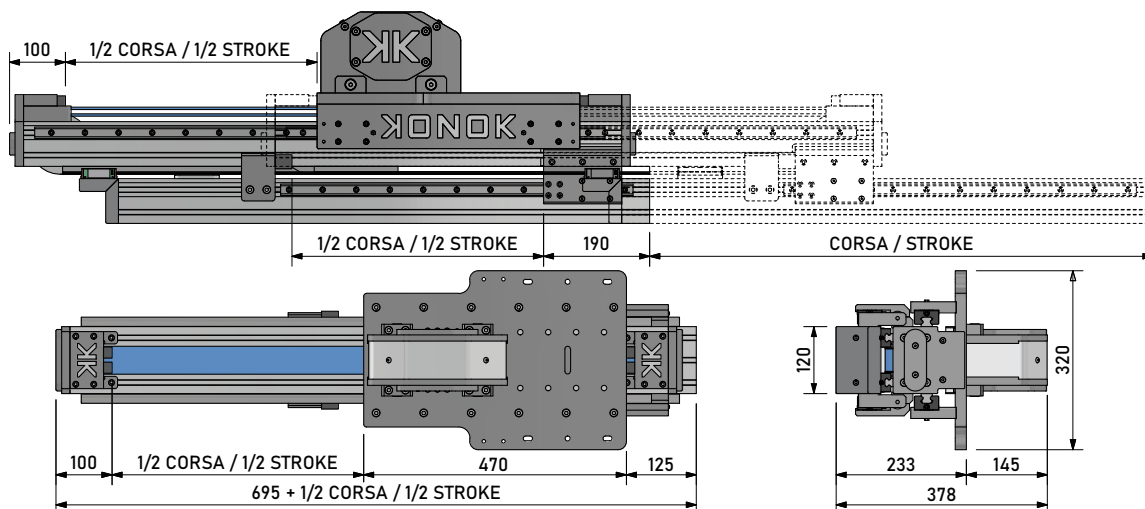

MAGGIORI DETTAGLI PAGINA / MORE DETAILS PAGE 165



SEZIONE PORTANTE / STRUCTURAL SECTION

Momento d'inerzia Moment of inertia	I _x	226.65 cm ⁴
Momento d'inerzia Moment of inertia	I _y	490.62 cm ⁴
Modulo resistenza flessione Flexural Modulus	W _x	56.66 cm ⁴
Modulo resistenza flessione Flexural Modulus	W _y	81.77 cm ⁴
Peso lineare Linear Weight		8.3 Kg/m
Tipo cava Hollow Type		08-PK-20

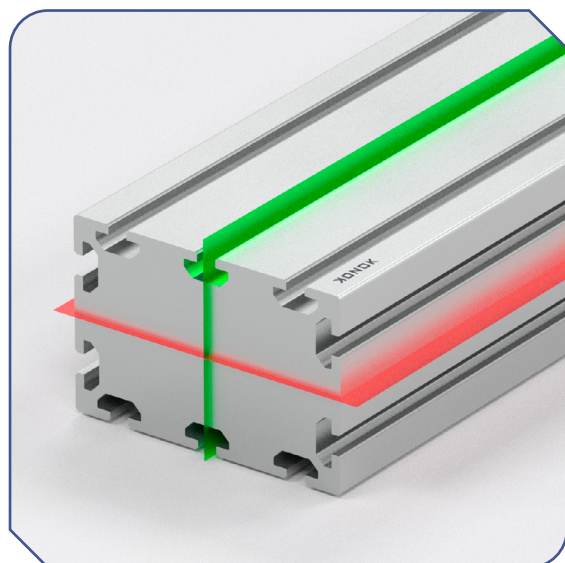

TP-K812

DIMENSIONI / DIMENSIONS

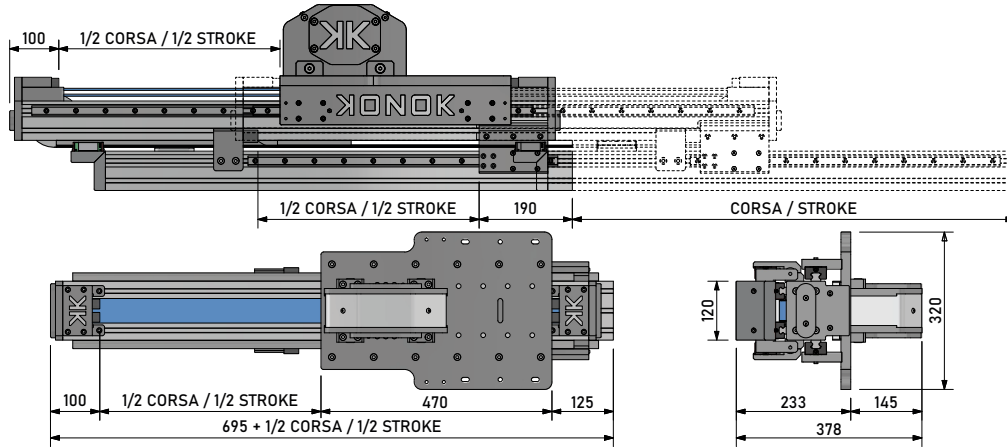

DIMENSIONI CARRO / CARRIAGE DIMENSIONS

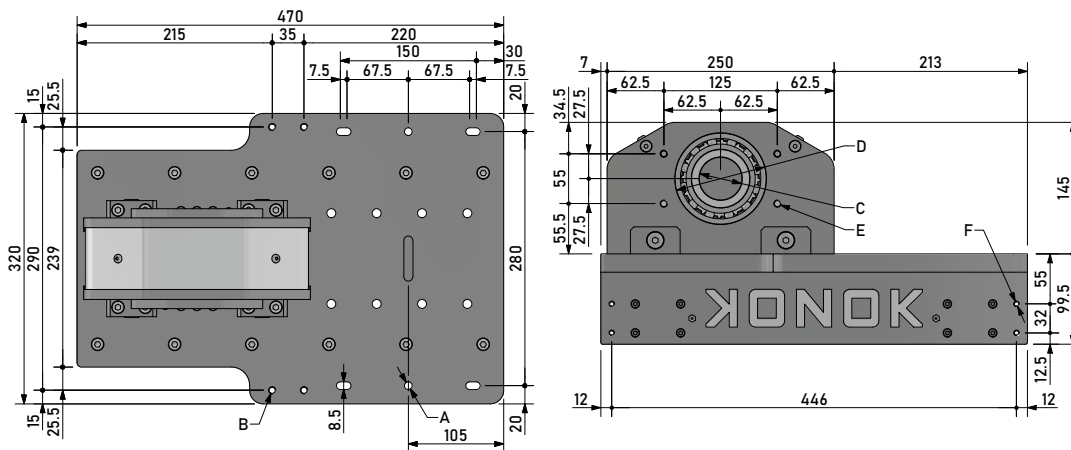

DIMENSIONI TESTATA MOTORE / MOTOR HEAD DIMENSIONS

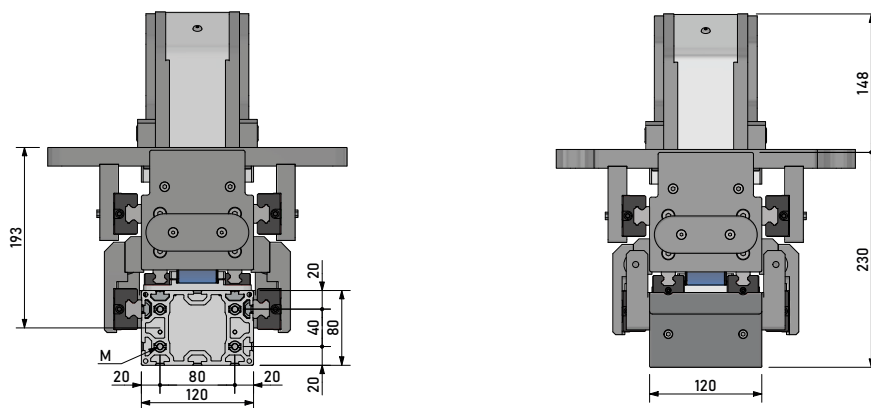

NOME / NAME	A	B	C	D	E	F	M
Ø - FILETTO / Ø - THREAD	2x Ø8.5	4x M8	Ø47 H7	Ø100 h7	4x M8	4x M8	4x M8
PROFONDITÀ / DEPTH	PASSANTE / THRU-HOLE	20	PASSANTE / THRU-HOLE	/	16	15	25
SPORGENZA / PROJECTION	/	/	/	2	/	/	/