

PR-M50D20

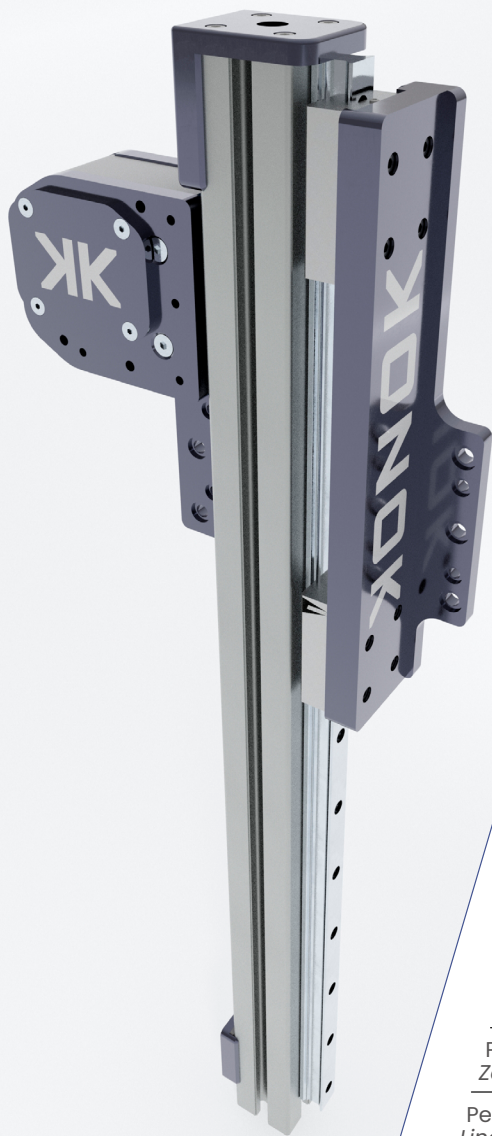

SPECIFICHE TECNICHE / TECHNICAL DATA

Versione unità Type Unit	Monoguida verticale Vertical monorail
Sezione portante Structure Section	50x50
Dimensioni guide Rail Size	15
Cinghia Belt	AT5-25
Velocità Speed	4 (m/sec)
Accelerazione Acceleration	30 (m/sec ²)
Ripetibilità Repeatability	0.1 (mm)

DATI PULEGGIA / PULLEY DATA

Puleggia Pulley	Z30
Ø Primitivo puleggia Ø Pulley Primitive	47.76 [mm]
Passo per giro puleggia Step for Pulley turn	150 [mm]
Coppia a vuoto Starting Torque	0.6 [Nm]

PESI / WEIGHTS

Modulo corsa zero Module zero travel	7 kg
Peso barra corsa zero Zero stroke bar weight	2.9 kg
Peso 100mm lineare Linear weight 100mm	0.6 kg
Peso del carro Carriage weight	4.1 kg

CONDIZIONI DI ESERCIZIO CONSIGLIATE / RECOMMENDED OPERATING CONDITIONS

Momento dinamico Dynamic Moment	Mx 82 Nm	My 597.2 Nm	Mz 597.2 Nm
Forze statiche Static forces	Fy 2370 N	Fz 2370 N	
Carico a trazione Tensile load	Fx 800 N		

* Il valore Fx si riferisce al carico applicabile alla puleggia, e non al valore di carico ammissibile dalla cinghia. Tale valore è calcolato sulla base del tipo di cinghia e del numero di denti della puleggia.
* The Fx value refers to the load applicable to the pulley, and not to the allowable load value of the belt. This value is calculated on the basis of the type of belt and the number of pulley teeth.

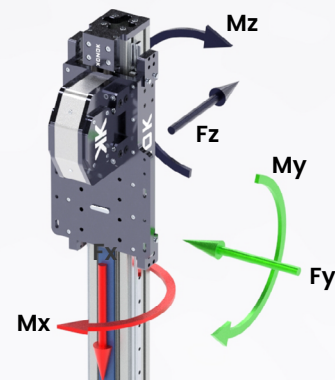

I valori dinamici indicati non corrispondono alle massime capacità di carico teoriche. Sono stati calcolati considerando fattori di sicurezza adatti alle automazioni industriali. In caso di sollecitazioni massime contemporanee si prega di contattare il servizio tecnico.
The dynamic values indicated do not correspond to the theoretical maximum load capacities. They have been calculated considering safety factors suitable for industrial automation. In case of simultaneous maximum stresses, please contact the technical service.

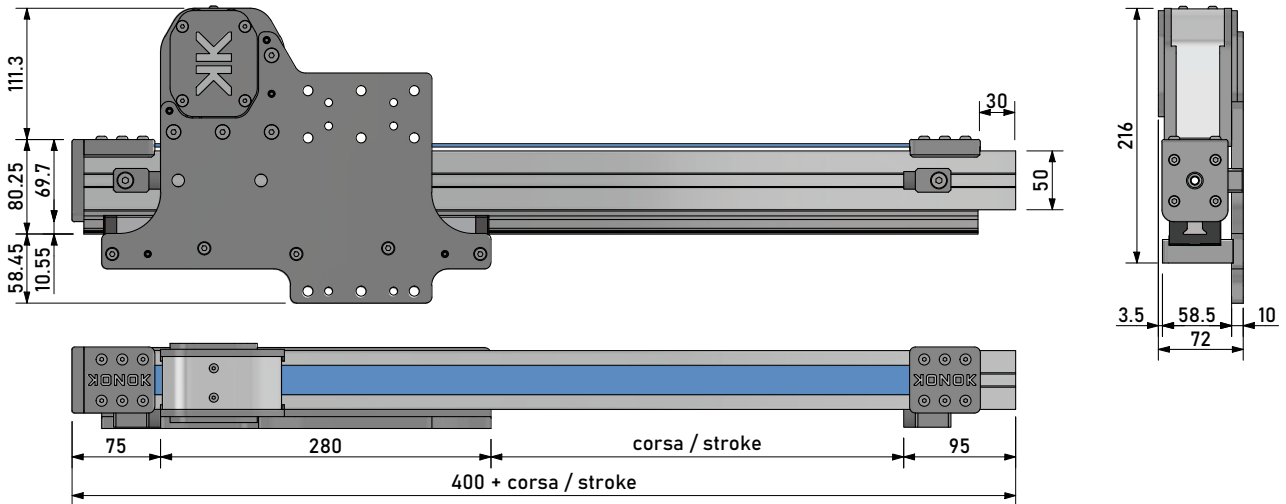

MAGGIORI DETTAGLI PAGINA / MORE DETAILS PAGE 138



SEZIONE PORTANTE / STRUCTURAL SECTION

Momento d'inerzia <i>Moment of inertia</i>	I_x	25.0 cm ⁴
Momento d'inerzia <i>Moment of inertia</i>	I_y	25.0 cm ⁴
Modulo resistenza flessione <i>Flexural Modulus</i>	W_x	10.0 cm ⁴
Modulo resistenza flessione <i>Flexural Modulus</i>	W_y	10.0 cm ⁴
Peso lineare <i>Linear Weight</i>		3.0 Kg/m
Tipo cava <i>Hollow Type</i>	 10.6-PG-22.5	

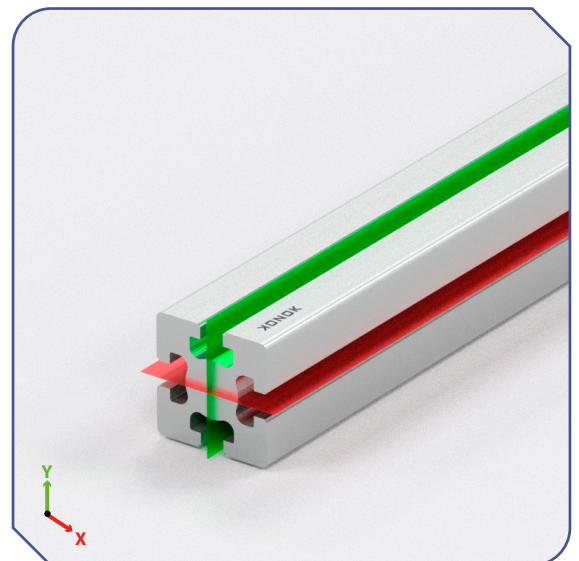

PR-M50D20

DIMENSIONI / DIMENSIONS

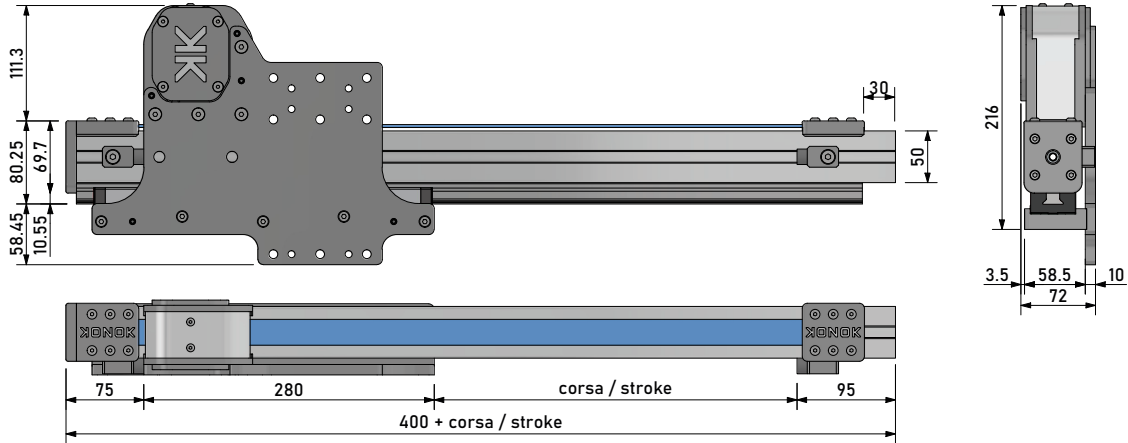

DIMENSIONI CARRO / CARRIAGE DIMENSIONS

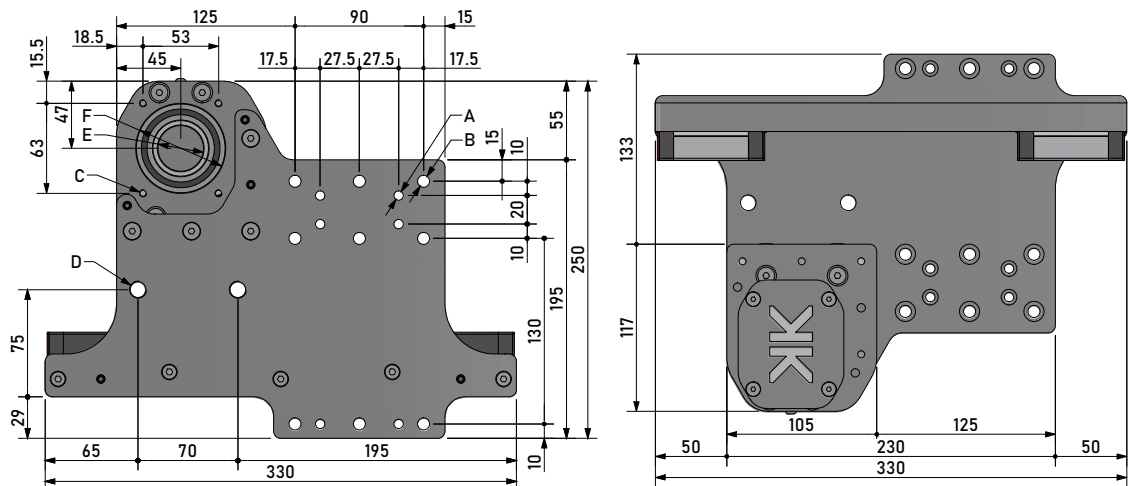

DIMENSIONI TESTATA MOTORE / MOTOR HEAD DIMENSIONS

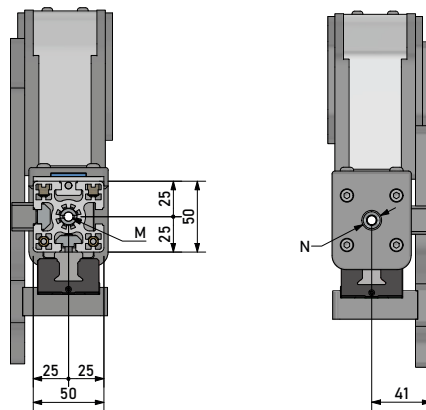

NOME / NAME	A	B	C	D	E	F	M	N
Ø - FILETTO / Ø - THREAD	6x Ø6.6	9x Ø8.5	4x M5	2x M12x1	Ø32 H7	Ø62 h7	M8	Ø14
PROFONDITÀ / DEPTH	PASSANTE / THRU-HOLE	PASSANTE / THRU-HOLE	10	PASSANTE / THRU-HOLE	PASSANTE / THRU-HOLE	/	25	PASSANTE / THRU-HOLE
SPORGENZA / PROJECTION	/	/	/	/	2	2	/	/